

SPECIAL FEATURE: AVAILABLE WITH FEMALE INLET AND MALE OUTLET IF REQUIRED

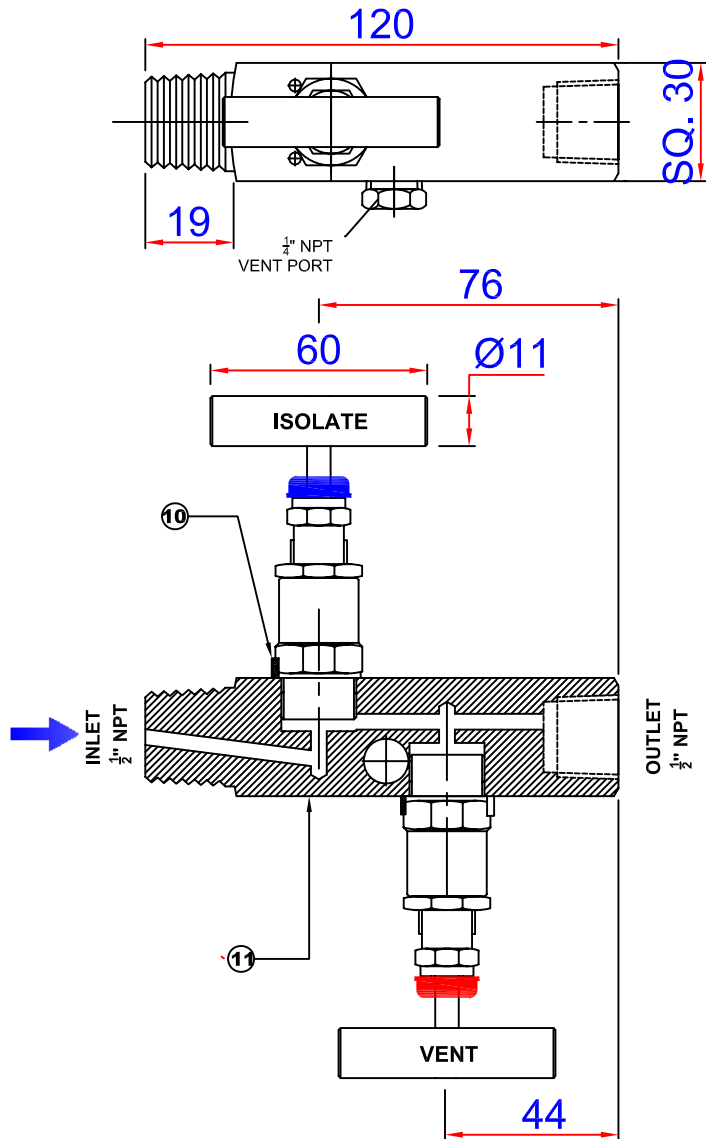

NO	DESCRIPTION	QTY	MATERIAL
1	SET SCREW	1	SS
2	HANDLE	1	SS
3	GLAND NUT	1	SS 316
4	LOCK NUT	1	SS
5	BONNET	1	SS 316
6	GLAND PACKING	1	PTFE
7	WASHER	2	SS 316
8	STEM	1	SS 316
9	DISC	1	SS 316
10	LOCK PIN	1	SS
11	BODY	1	SS 316
12	DUST COVER	1	PVC

DEATILS OF SUB-ASSY

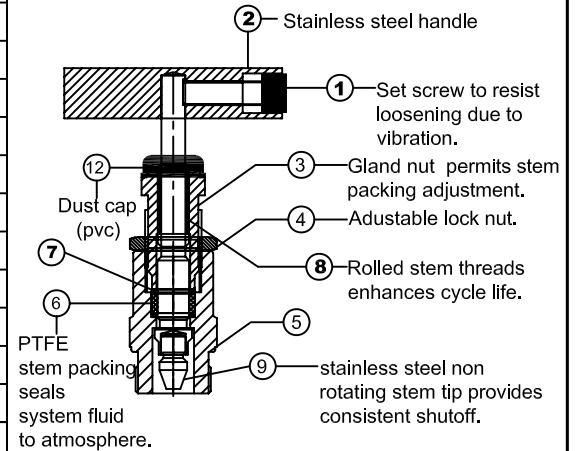

DESIGN FEATURES :

- STEM SEAL BELOW ACTUATING THREADS TO PREVENT CONTAMINATION, GAULING OF THREADS.
- METAL TO METAL BONNET SEAL FOR PRESSURE TIGHTNESS EVEN AT ELEVATED TEMPERATURES.
- APPROXIMATE WEIGHT - 1 KG

BONNET ASSEMBLY :

- SCREWED BONNET DESIGN.
- SPINDLE - GROUND & THREAD ROLLED.
- SPINDLE TIP - NON ROTATING TIP SHUT OFF TYPE
- BONNET PUSHER - DULY MACHINED FOR SMOOTH STEM CYCLE.
- DUST CAP - PROTECTS STEM THREADS FROM EXTERNAL CONTAMINATION.

NOTE: DIFFERENT END CONNECTIONS AND MATERIAL GRADES OFFERED ON REQUEST.

TEST PRESSURES:

	HYDRAULIC	PNEUMATIC (NITROGEN)
BODY	9000 PSI	1000 PSI
SEAT	6600 PSI	1000 PSI

FEATURES :

- SIZE : 1/2 "
- WORKING PRESSURE : 6000 PSI
- TEMPERATURE RATING : PTFE 450° F (232° C).
- MATERIAL OF CONSTRUCTIONS : SS 316.
- STEM PACKING : PTFE.
- CHOICE OF PACKING MATERIALS FOR ELEVATED TEMPERATURES.
- ALL VALVES ARE 100% FACTORY TESTED.

TESTING :

- HYDROSTATIC SHELL TEST IS PERFORMED AT 1.5 TIMES THE WORKING PRESSURE.
- OPTIONAL TESTS ARE AVAILABLE ON REQUEST.

LUBRICATION :

- DYE MOLLY SULPHIDE.

CLEANING & PACKAGING :

- ALL COMPONENTS ARE ULTRASONICALLY CLEANED PRIOR TO ASSEMBLY & TESTING.

SIZE : 1/2" NPT

BLOCK AND BLEED 180 DEG MF

BY	DATE	DIMENSIONS ARE FOR REFERENCE ONLY & SUBJECT TO CHANGE
DRAWN PRASHANT	14/08/2009	MODEL . NO :- IVI-BB-SQ-MF
CHD. RD	14/08/2009	
APPRD. RD	14/08/2009	



INDUSTRIAL VALVES
MUMBAI - 64