

110 ±1MAX.CLOSED & 115 ±1MAX.OPEN

101 ± 1.5

BILL OF MATERIAL

SR. NO.	DESCRIPTION	QTY	MATERIAL
1	SPINDLE	1	SS 410 / SS 316L
2	SPACER	1	SS 410 / SS 316L
3	GLAND PACKING	1	PTFE
4	SPACER	1	SS 410 / SS 316L
5	GLAND BUSH	1	SS 410 / SS 316L
6	GLAND NUT	1	A 105 / SS 316L
7	HANDLE	1	CS
8	HANDLE WASHER	1	CS / SS
9	HANDLE NUT	1	CS
10	BODY	1	A 105/A 182 F316L

FEATURES :

- RUGGED FORGED BODY / ULTRA CHECKED.
- LOW OPERATING TORQUE.
- SCREWED NPT THREADS
- ACCURATE FLOW CONTROL
- WORKING PRESSURE 10000 PSI
- ALL VALVES ARE 100% FACTORY TESTED.

TESTING :

- HYDROSTATIC SHELL TEST IS PERFORMED AT 1.5 TIMES THE WORKING PRESSURE.
- OPTIONAL TESTS ARE AVAILABLE ON REQUEST.

LUBRICATION :

- DYE MOLLY SULPHIDE.

CLEANING & PACKAGING :

- ALL COMPONENTS ARE ULTRASONICALLY CLEANED PRIOR TO ASSEMBLY & TESTING.

DETAILS OF SUB-ASSY

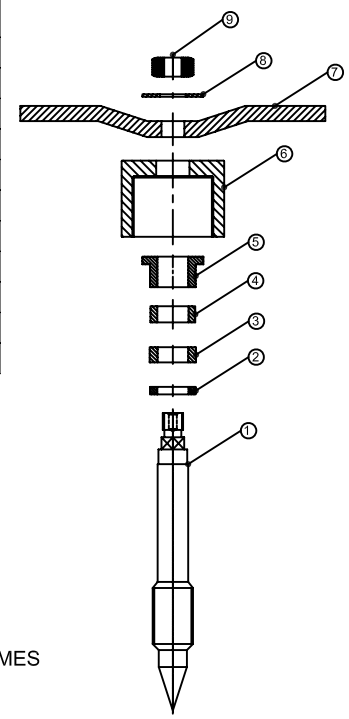

TEST PRESSURES:

	HYDRAULIC	PNEUMATIC
BODY	15000 PSI	1000 PSI
SEAT	11000 PSI	1000 PSI

SIZE : 1/2" NPT

Y-TYPE NEEDLE VALVE

BY	DATE	DIMENSIONS ARE FOR REFERENCE ONLY & SUBJECT TO CHANGE
DRAWN PRASHANT	14/08/2009	
CHD. RD	14/08/2009	
APPRD. RD	14/08/2009	MODEL . NO :- IVI-HPS-Y



INDUSTRIAL VALVES
MUMBAI - 64